

OPERATION

Application of voltage to the input of the timer initiates the OFF time. Upon completion of the OFF time, the load energizes and the ON time begins. Upon completion of the ON time, the load de-energizes and the cycle is complete. Reset during or after the time periods is accomplished by removal of the input voltage. The OFF/ON time periods are independently adjustable.

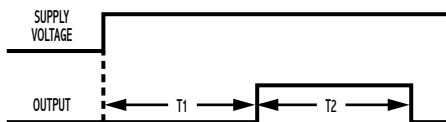

UL®
E55826

Delayed Interval Solid-State Output

WIRING

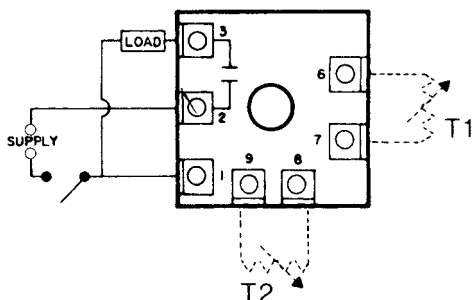

DIMENSIONS (INCHES)

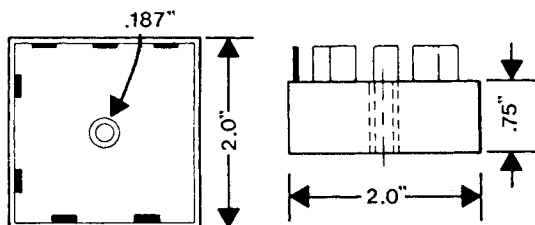

MODEL NUMBER

MODEL NUMBER	TSH		A		C	
SUPPLY VOLTAGE						
24 VAC		24				
120 VAC		120				
240 VAC		240				
TYPE OF OPERATION						
Fixed				F		
External Resistor Adjustable; See page 73 for resistor selection.				R		
DELAY PERIOD						
See page 73 for standard ranges available						

Example: TSH-120-AFC-015—Delayed interval, 120 VAC, both delays fixed at 15 seconds, UL recognized.

SPECIFICATIONS

TIMING RANGES	Virtually unlimited. See page 73 for standard ranges available.	
OUTPUT RATING	Solid-state, SPST-N.O. 1 amp resistive; 1250 VA inrush, 125 VA run @ 120 VAC, inductive.	
TIMING TOLERANCES	Minimum Setting	+0 – 20%
	Maximum Setting	±10%
REPEATABILITY	1% maximum; no first cycle effect	
RESET TIMES	Before Time Out	100 mSEC
	After Time Out	50 mSEC
RECYCLE TIME	40 mSEC	
SUPPLY VOLTAGE	24, 120, or 240 VAC, 50/60 Hz; ±10%	
FALSE TRANSFER	No	
ENCLOSURE	Surface mounted; totally encapsulated with a high quality epoxy for environmental protection.	
TEMPERATURE RATING	Operate	32° to 131°F (0° to +55°C)
	Storage	-49° to 185°F (-45° to +85°C)
TERMINATIONS	1/4" quick disconnect terminals	
WEIGHT	NET: .96 oz Shipping: 1.28 oz.	

TIMING RANGE SELECTION

CAUTION: DO NOT PROGRAM WITH POWER ON! WIRE FOR ONE TIMING RANGE ONLY!

4 different ranges can be obtained by either leaving 2 designated terminals unconnected or by connecting them to the appropriate terminals shown below. Because the Time Delay programming is the same regardless of the mode of operation only the wiring connections affecting the Time Delay are shown here.

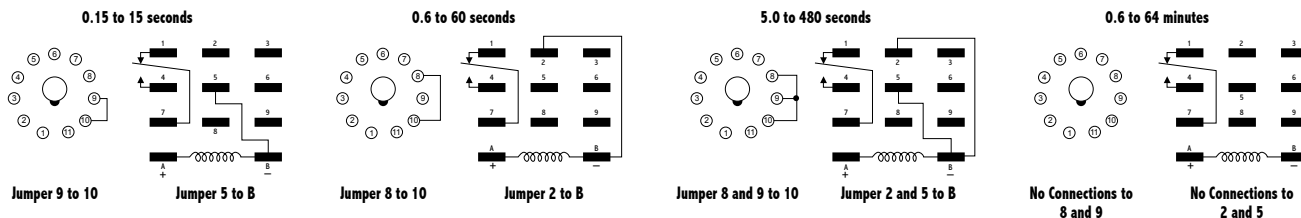

OPERATION—WIRE FOR ONE MODE ONLY!

INTERVAL: When voltage is applied to the input terminals, the relay energizes and the time delay begins. Upon completion of the delay period, the relay de-energizes. Reset during or after the delay period is accomplished by removal of the supply voltage.

ON-DELAY: The time delay begins when power is applied to the input. Upon completion of the delay period, the relay energizes. Reset during or after the delay period is accomplished by removal of the input voltage. The timer will not false transfer if supply voltage is removed prior to completion of the delay period.

OFF-DELAY: Voltage is continuously applied to the input. An external isolated switch controls the timer. When closed, the relay energizes. Opening the switch initiates the delay period. Upon completion of the delay period, the relay de-energizes. If the control switch recloses during the delay period, the relay remains energized and the timer resets to zero.

SINGLE-SHOT: Voltage is continuously applied to the input. An external isolated switch controls the timer. When closed (momentary or maintained), the relay energizes and the delay period begins. Upon completion of the delay period, the relay de-energizes.

FLASHER—OFF TIME FIRST: When supply voltage is applied to the input, the OFF time begins. Upon completion of the OFF time, the relay energizes and the ON time begins. Upon completion of the ON time, the relay de-energized and one cycle is complete.

This OFF/ON cycling continues until supply voltage is removed from the input. The OFF time always equals the ON time.

FLASHER—ON TIME FIRST: When power is applied to the input, the relay energizes and ON time begins. Upon completion of the ON time, the relay de-energizes and the OFF time begins. Upon completion of the OFF time, the relay energizes and one cycle is complete. This ON/OFF cycling continues until supply voltage is removed from the input. The ON time always equals the off time.

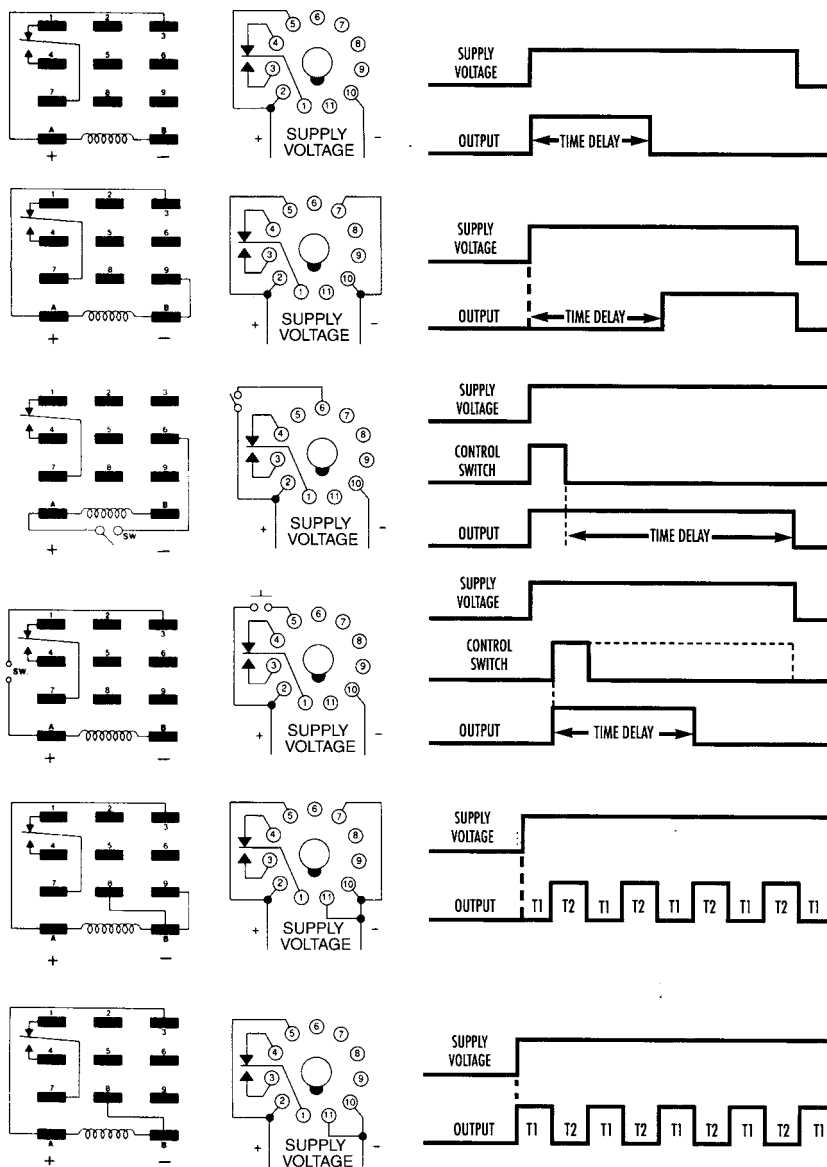

STANDARD DELAY RANGES AVAILABLE

The chart below shows the standard adjustable time delay ranges available. The part number suffix equals the maximum adjustable delay period of the timer. No letters following the suffix number indicates the delay period in seconds; an M indicates minutes; and an H indicates hours.

STANDARD DELAY RANGE CHART

PART NUMBER SUFFIX	MINIMUM SETTING	MAXIMUM SETTING
010	0.1 seconds	10 seconds
030	0.3 seconds	30 seconds
060	0.6 seconds	60 seconds
100	1 second	100 seconds
200	2 seconds	200 seconds
300	3 seconds	300 seconds
600	6 seconds	600 seconds
900	9 seconds	900 seconds
30M	18 seconds	30 minutes
60M	36 seconds	60 minutes
90M	54 seconds	90 minutes
2H	1.2 Minutes	2 hours
4H	2.4 Minutes	4 hours
8H	4.8 Minutes	8 hours
12H	7.2 Minutes	12 hours
16H	9.6 Minutes	16 hours
20H	12 Minutes	20 hours
24H	14.4 Minutes	24 hours

Longer delays available upon request. Consult Factory

EXTERNAL RESISTANCE SELECTION

On models specified as having the external resistor adjustability feature, the delay period is set by placing resistance across designated pins or terminals. One meg ohm resistance provides the maximum delay on all models. The minimum delay is obtained by jumping the terminals together.

The resistor or potentiometer chosen should be a 1/4 watt or larger.

To determine the resistor value required for a specific time delay, use the following formula:

$$R_{ext} = (T_{des}/T_{max}) \times 1000$$

R_{ext} = Resistance value required to obtain T_{des} (in K ohms)

T_{des} = Desired time delay

T_{max} = Maximum delay period of the timer

Example: Model TDC-120-ARC-300; find the external resistance value required for a 240 second delay:

$$R_{ext} = \frac{240}{300} \times 1000 = 800 \text{ K ohms}$$

“FIXED” DELAY OPTION

Most ATC Diversified timers are available with the delay period factory preset (“fixed”) for some specified duration. When this option is ordered, the part number should have an “F” in the Type of Operation designation: and the last digits should specify the desired time delay in seconds (S), minutes (M), or hours (H).

Example: TDC 120-AFA-30M—delay-on-operate, 120 Volts AC or DC, 8-pin octal plug-in package with a 30 minute fixed delay.

OFF/ON DELAY TIMERS

Included in ATC Diversified’s broad line of timers are six (6) models that feature independent OFF/ON delay adjustments. They are TDF, TDH, TDI, TSF, and TSH. Notice in the ordering information section on each of their respective pages the timing range is specified by a three (3) digit suffix. This indicates that both the OFF and ON delay periods have the same timing ranges. Example: TDF-120-ALA-300: Both OFF and ON delay periods are independently adjustable from 3 to 300 seconds.

In the event that two (2) separate delay ranges would be required, the part number is modified to add a slash (/) followed by three (3) more digits. Since the OFF delay (TI) is first in all models, it is specified first in the part number. Example: TDF-120-ALA-12H/30M: the OFF delay is adjustable from 7.2 minutes to 12 hours and the ON delay is adjustable from 18 seconds to 30 minutes.

NOTE: Combinations of various “types of operation” are available: fixed/adjustable, knob/lock nut, etc. Consult factory.

MODEL NUMBER

MODEL NUMBER	T						
TIME DELAY							
SERIES							
Relay Output	D,U						
Solid State Output	S						
MODE OF OPERATION							
SUPPLY VOLTAGE							
24 Volts		24					
120 Volts		120					
240 Volts		240					
TYPE OF VOLTAGE							
AC			A				
DC			D				
TYPE OF OPERATION							
Knob Adjustment				K			
Lock Nut Adjustment				L			
Fixed (Factory Preset)				F			
External Resistor Adjustable				R			
ENCLOSURE STYLE							
8 or 11-pin Round Plug-in					A		
Blade Plug-in					B		
Potted Cube					C		
DELAY PERIOD							
See Standard Delay Range Chart							

NOTE: Not all time delays are available with each option shown above. The specific options for each timer type are described on their respective pages.